

AP-553

MIL-1553 DataPHY Data Recorder



The AP-553 DataPHY records MIL-1553 databus traffic from military equipment. This recorded data can be securely shared with other equipment, either in real-time or post flight. In a 1 by 2 by 3 inch enclosure it is the world's smallest MIL-1553 data collection system. Within a very small form factor, the MIL-1553 DataPHY contains dual MIL-1553 receivers – capable of recording traffic from both the A and B buses on a single MIL-1553 data bus – a Gigabit Ethernet interface, an 802.11ac WiFi Radio, an integrated antenna, and 120 GB of local storage. Its size and weight facilitates a large number of installation options.

Features

- Lightweight and compact
- Record traffic from both A and B buses on a MIL-1553 databus
- Collected data can be monitored as part of an avionics Intrusion Detection System
- Data can be forwarded to Electronic Flight Bag software on a connected tablet
- Includes a customized version of the SystemX Operating System
- Integrated antenna
- 120GB for data storage

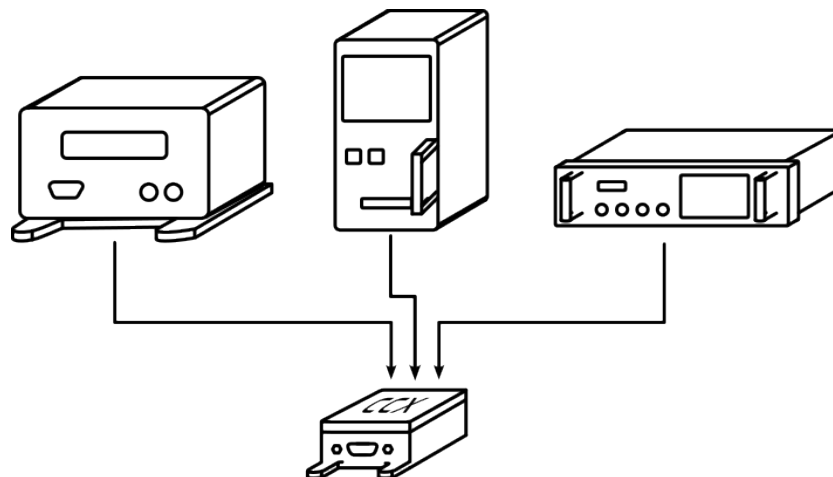

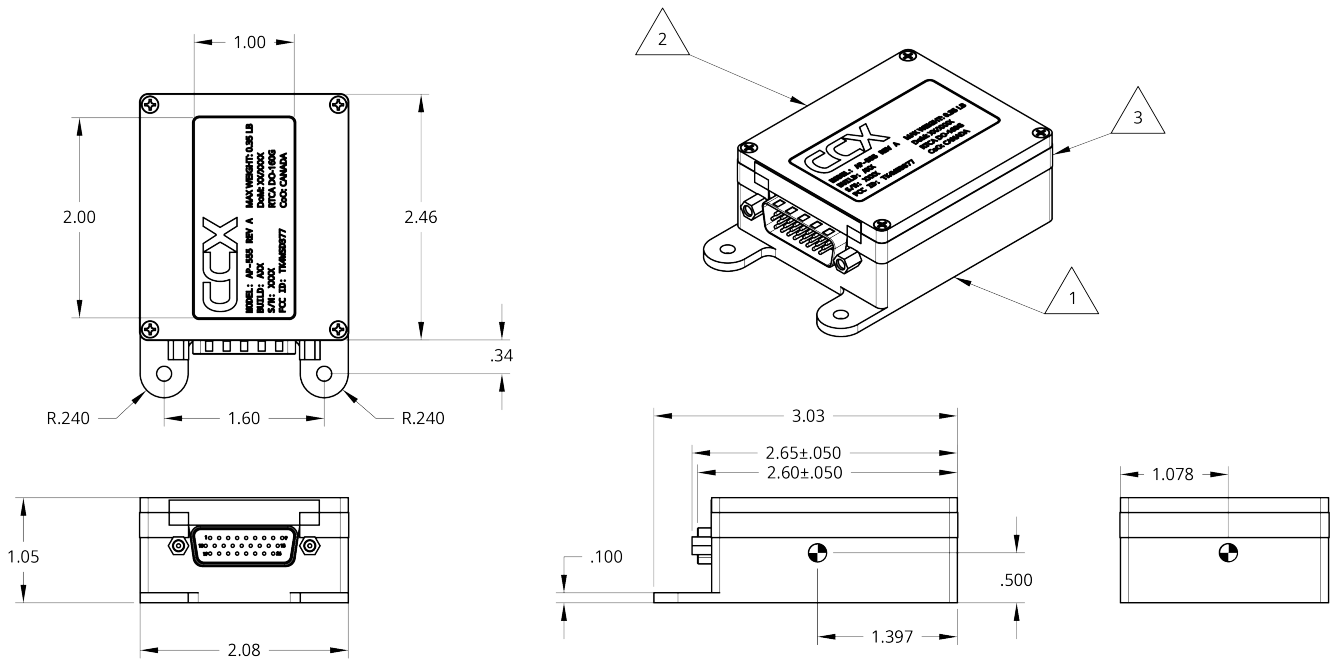

Technical Information

Dimensions	2.46"L x 2.08"W x 1.05"H
Weight	0.35lb
Mounting Provisions	2 mounting holes for #6 bolts or screws; flange mount. Option to install in 2 or 4 MCU form factor with an IK-350
Connectors	MIL-DTL-24308G 26-pin Male HD D-sub
Operating Voltage	28VDC
Typical Power Consumption	2.5W
Maximum Power Consumption	5W
WiFi ¹	IEEE802.11ac/n/a/b (WiFi 5), 2.4GHz/5GHz, radio with radio enable discrete input
Ethernet	10/100/1000 BASE-T IEEE 802.3 Compliant Ethernet Ports with: ACS, Automatic MDI/MDIX crossover, Automatic polarity correction, and IEEE 802.3u compliant auto negotiation
MIL-1553	MIL-1553 RX on both A and B channels
Discrete GPIO	ARINC-628 GND/Open and High/Low Sensing Discrete Inputs/Outputs
Data Storage	120GB
Environmental Qualifications	RTCA DO-160G

¹All DataPHYS are available with hardware disabled WiFi radios for applications with security requirements that don't allow for wireless connections.

Interfaces

QTY	Interfaces	Standards
1	Ethernet	1000/100/10BASE-T (IEEE 802.3ab/u/i)
1	WiFi (Integrated Antenna)	IEEE 802.11ac/n/b/a (2.4 GHz/5GHz)
1	Databus Receivers	MIL-1553
1	Radio Disable Discrete Inputs	ARINC-628
1	Discrete Output	ARINC-628
1	Discrete Input	ARINC-628
1	Power	28V DC

Contact us:

 ccxtechnologies.com

 info@ccxtechnologies.com

 +1 (613) 695-9434

Powered
by

